

KUS series ultrasonic transmitter

1. Dimensions

Unit in the diagram is mm.

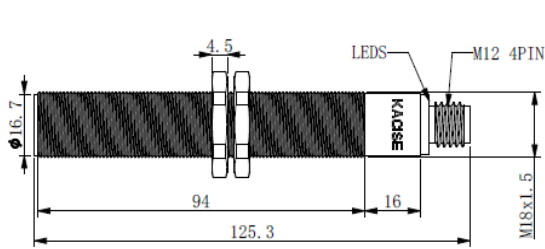

M18 series transmitter dimensions

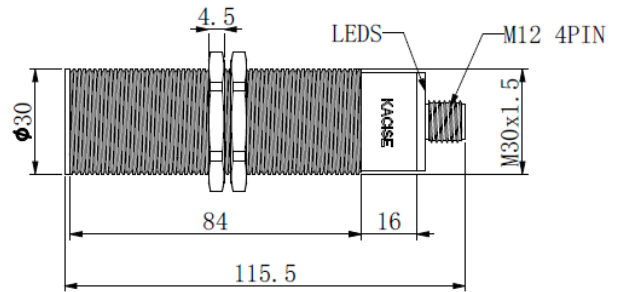

M30 type1 series transmitter dimensions

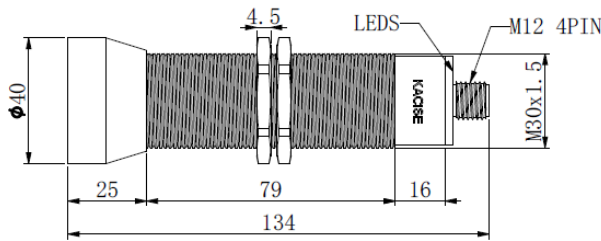

M30 type2 series transmitter dimensions

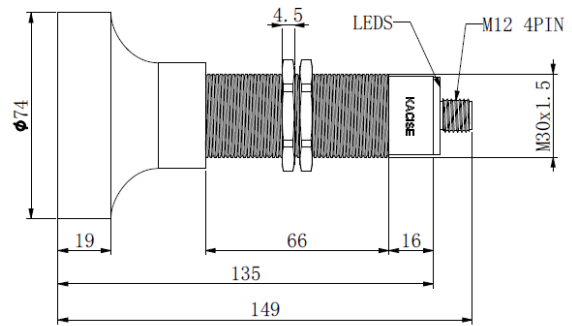

M30 type3 series transmitter dimensions

2. Electronic interface and signals definition

Switch Output NPN wiring diagram
NPN output

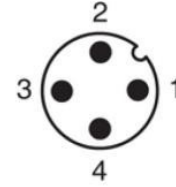
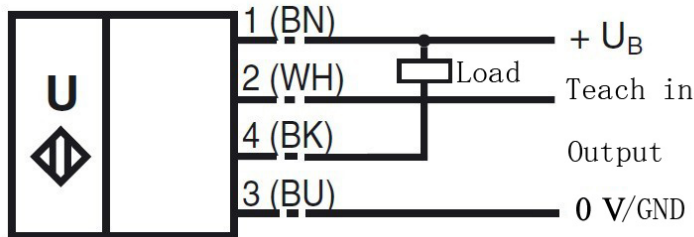

Analog output wiring diagram
0-10V

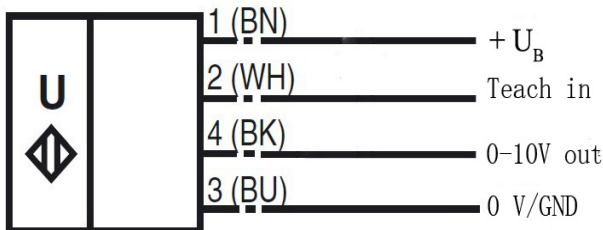

PNP switch out put Wiring diagram:
PNP Type

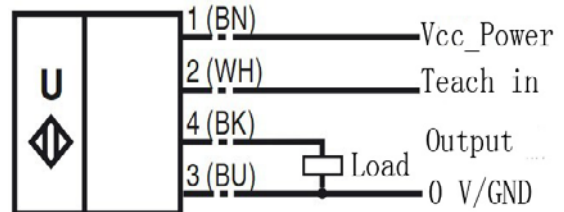

RS485 wiring diagram
RS485 output

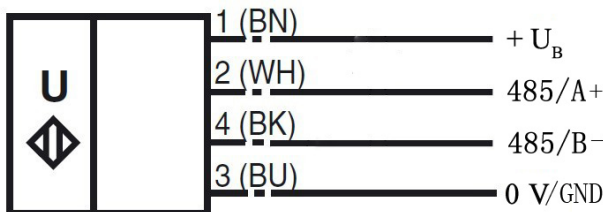

4-20mA output wiring diagram
4-20mA output

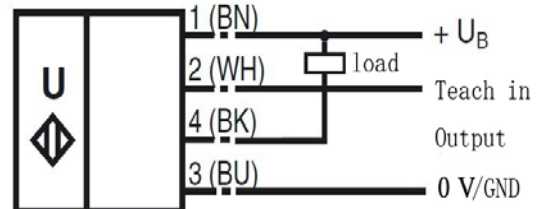

3. Parameter

General specifications

M18	
Sensing range	100... 1000 mm
Adjustment range	100....1000mm
Unusable area	0 ... 100 mm
Standard target plate	100 mm x 100 mm
Transducer frequency	approx.220 kHz
Response delay	approx. 10 ms

M30-type1	
Sensing range	200... 2000 mm
Adjustment range	200....2000mm
Unusable area	0 ... 200 mm
Standard target plate	100 mm x 100 mm

Transducer frequency	approx.150 kHz
Response delay	approx. 10 ms

M30-type2	
Sensing range	200... 3000 mm
Adjustment range	200....3000mm
Unusable area	0 ... 150 mm
Standard target plate	100 mm x 100 mm
Transducer frequency	approx.70 kHz
Response delay	approx. 20 ms

M30-type3	
Sensing range	400... 6000 mm
Adjustment range	400....6000mm
Unusable area	0 ... 300 mm
Standard target plate	100 mm x 100 mm
Transducer frequency	approx.50 kHz
Response delay	approx. 40 ms

Indicators/operating means

LED blue	Flashing :program can be acted, this status The Blue led will flash around 5 minute after the sensor power on, indicate the sensor can be programed, and then the blue led will perpetually turn on. To indicate the power status.
LED yellow	indication of the switching state flashing: during program function object detected
LED red	Normal working: light on indicate error detected. Programing: flashing, echo lost, that means the sensor covered or no object in the front of the sensor,

Electrical specifications

Operating voltage U_B	13 ... 30 V DC , ripple 10 %SS
No-load supply current I_0	≤ 45 mA

Input

Input type	1 TEACH-IN input
	operating range A1: 0V/GND ... +1 V, operating range A2: +6 V ...
	input impedance: > 4.7 k Ω ; TEACH-IN program pulse: ≥ 1 s

Output

Output type	1 switch output E4, NPN NO/NC, programmable 2 switch output E4, PNP NO/NC, programmable 3 Analog 0-10V output E4 programmable. 4 Analog 4-20mA output E4 programmable 5 RS485 output E4 programmable.
Rated operating current I_e	200 mA , short-circuit/overload protected
Default setting	Switching point A1:150mm Switching point A2: 1000mm
Voltage drop	$\leq 2.5 V$
Repeat accuracy	$\leq 1 \%$
Switching frequency f	$\leq 13 \text{ Hz}$ (customized for high frequency version)
Range hysteresis H	5 % of the set operating distance
Temperature influence	$\pm 1.5\%$ of full-scale value

Ambient conditions

Ambient temperature	-25...70°C (248...343K)
Storage temperature	-40...85°C (233...358K)

Mechanical specifications

Connection	V1 connector(M12×1),4-pin
Protection degree	IP67
Material Housing	brass, nickel-plated
Transducer	epoxy resin/hollow glass sphere mixture; foam polyurethane, cover PBT

4. Description of Sensor Functions

Adjusting the switching points and the analog output.

The switch output type and analog output type sensor can be programmed as the user want. There is 8 types of output functions can be programmed.

All the teach routine as follows,

step 1 teach one point with the related teach in condition(High level voltage or GND). step 2 choose a different distance(not the same with step1) point and a different teach in condition(not same with the step1). The program routine must be finished during the blue led flashing, the default value will be efficient if the not.

The ultrasonic sensor features a switch output with two teachable switching points. These are set by applying the supply voltage - UB or + UB to the TEACH-IN input. The supply voltage must be applied to the TEACH-IN input for at least 1 s. LEDs indicate whether the sensor has recognized the target during the TEACH-IN procedure. Switching point A1 is taught with - UB, A2 with +UB. Five different output functions can be set.

1. Window mode normally-open and liner mode positive slope output function.
2. Window mode normally-closed and liner mode negative slope output function.
3. Single switching point, normally-open function.
4. Single switching point, normally-closed function.
5. Single switch point with hysteresis gap normally-open function.
6. Single switch point with hysteresis gap normally-closed function.
7. Detection of object presence-normal open function.
8. Detection of object presence-closed open function.

Switching point, Setting distance only after power on. The internal clock can assure can't be

changed after 5 minutes after power on. If want to change the switching point, the user can only setting the request distance after power restart.

For the RS485 output type.

There is 2 kinds of working style,

One for auto measure, the sensor will measure the distance or level repeatedly, and the measurement period can be set by the uart. The measure result can be fetched every time.

The other style is power save mode when the sensor is sleep, until the sensor received the inquiry command with pre-code. Communication protocol is Modus-RTU.

For example the measure result can be read by access the register 0x101 by Modbus protocol.

For more information please contact us for the software engineering guide.

LED displays			
		Programming time	Working time
Red LED	ON	--	Error accured
	OFF	Working well	Working well
	Flash	Doing the echo lost program, For Single switching point, program, or Detection of object.	-----
Yellow LED	ON	----	Object detected
	OFF	-----	Echo lost
	Flash	Teach in for the status ready, That means the sensor has locked the set distance for program	-----
Blue LED	ON	Power on	Power on
	OFF	Power off	Power off
	Flash	Program period indication, Only the blue led flashes the program routine can be done	Program can be carried on

1), Window mode normally-open and liner mode positive slope output function program routine diagram.

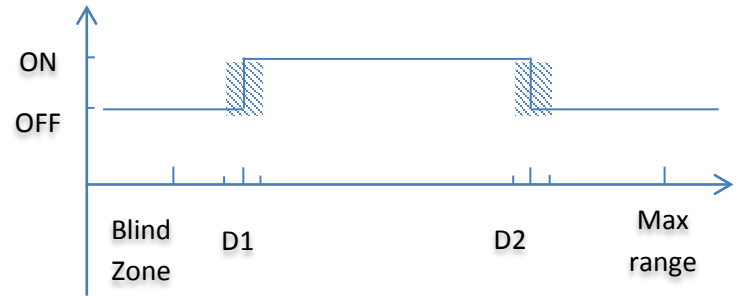
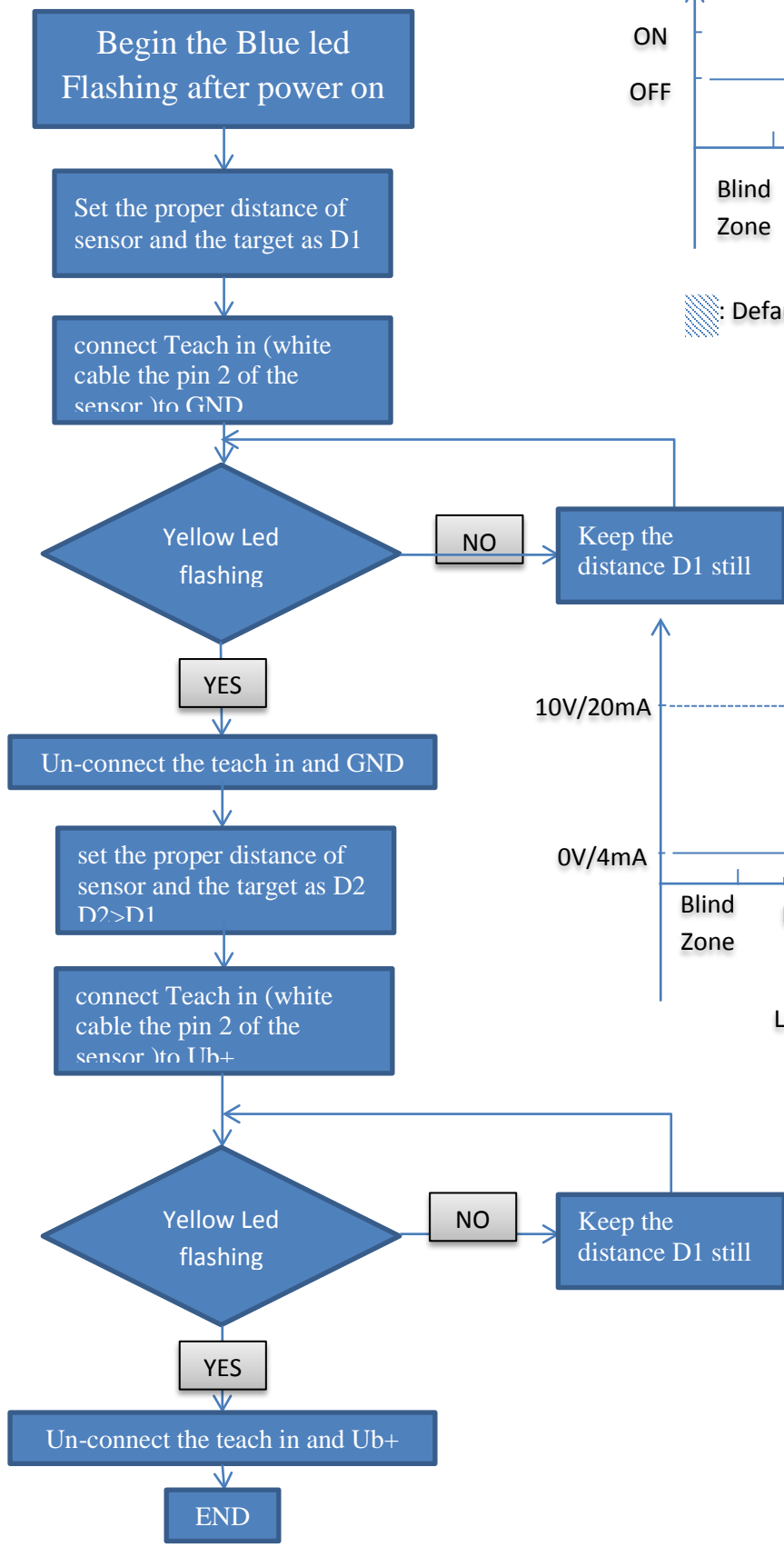

: Default 5% Hysteresis gap

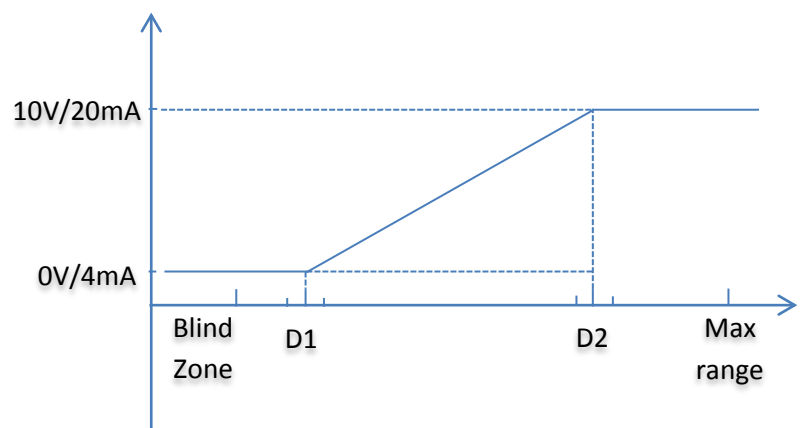

Liner output and Program diagram

2), Window mode normally-closed and liner mode negative slope output function program routine diagram.

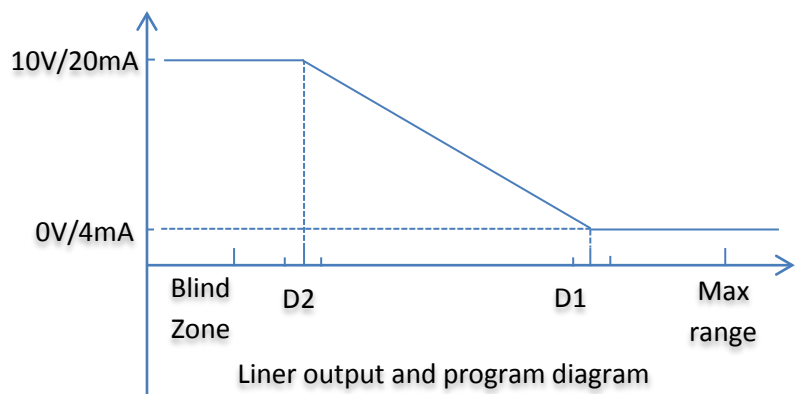
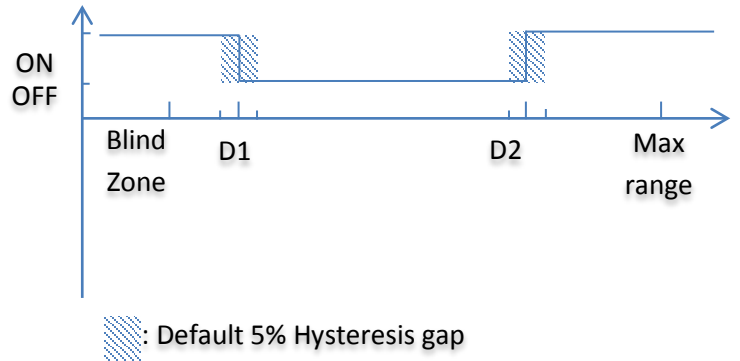
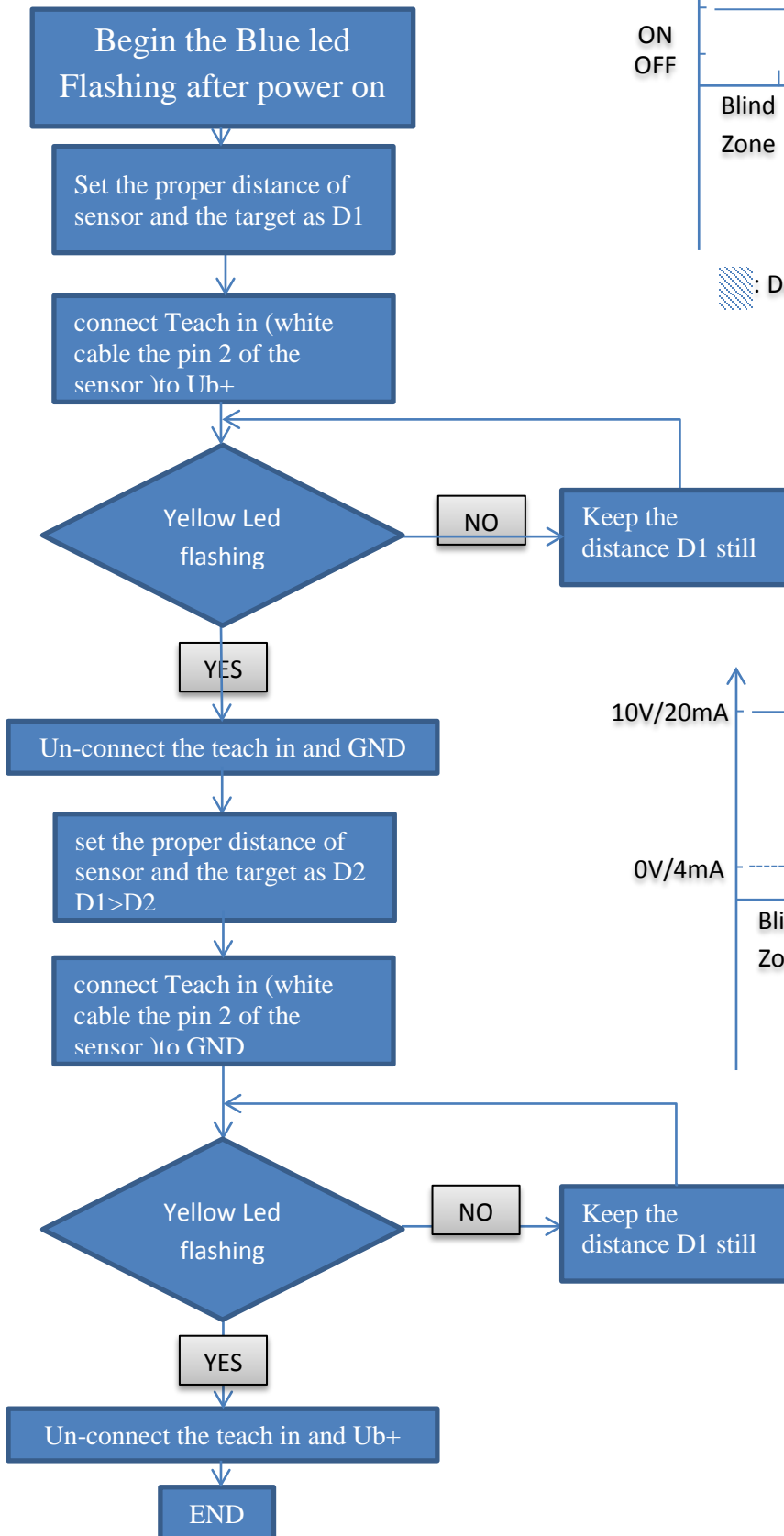

3), Single switching point, normally-open function program routine diagram.

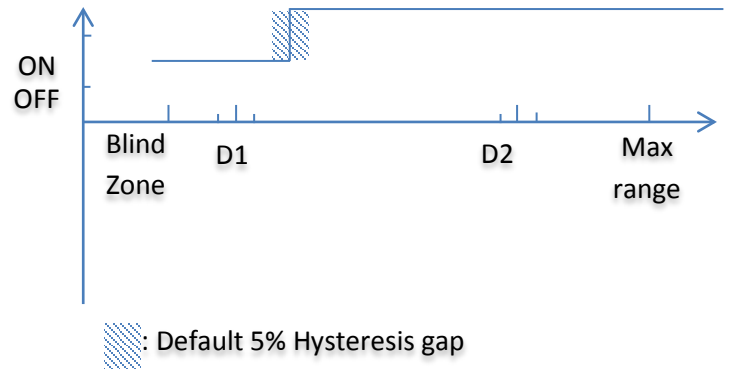
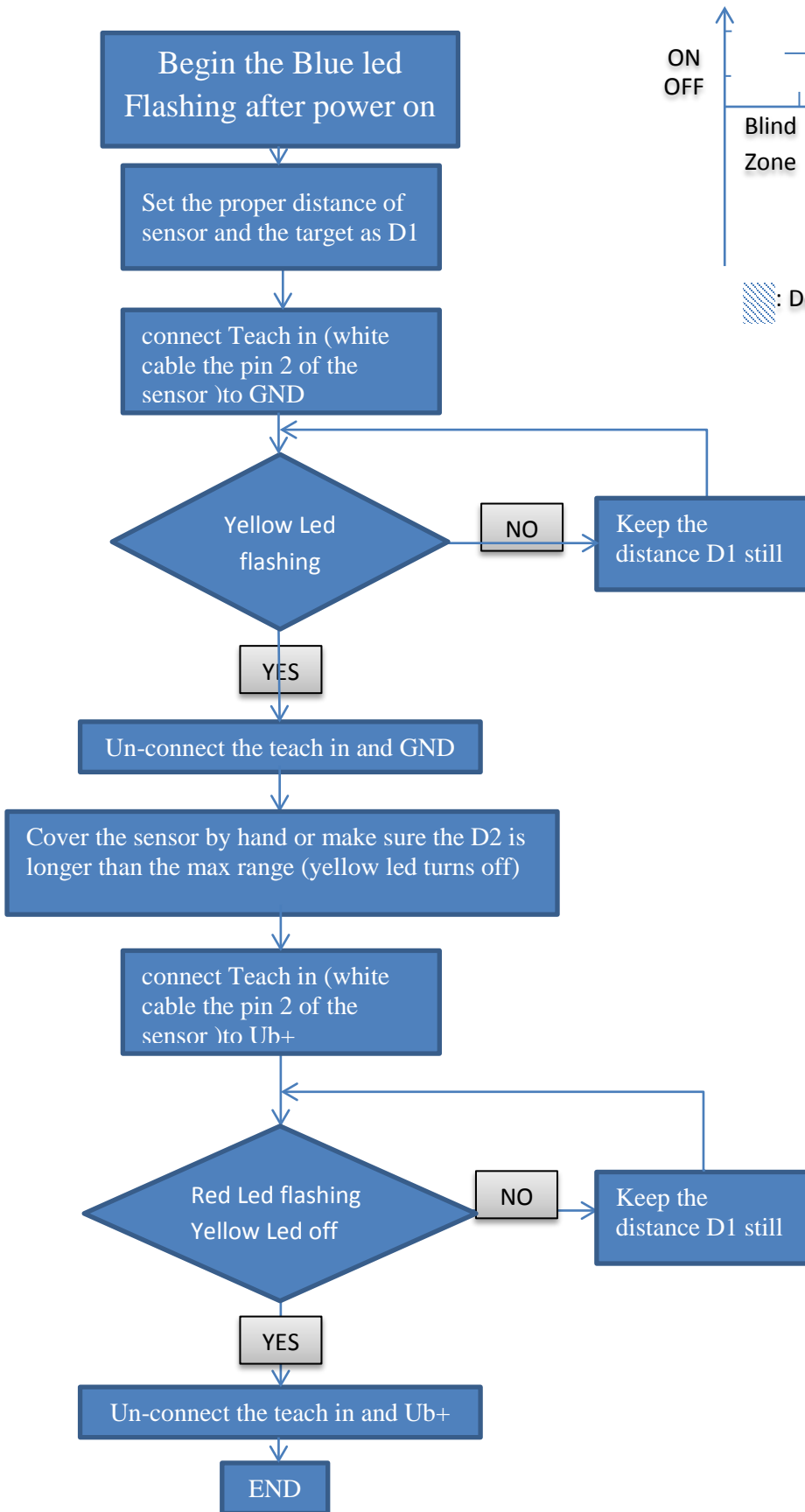

4), Single switching point, normally-closed function program routine diagram.

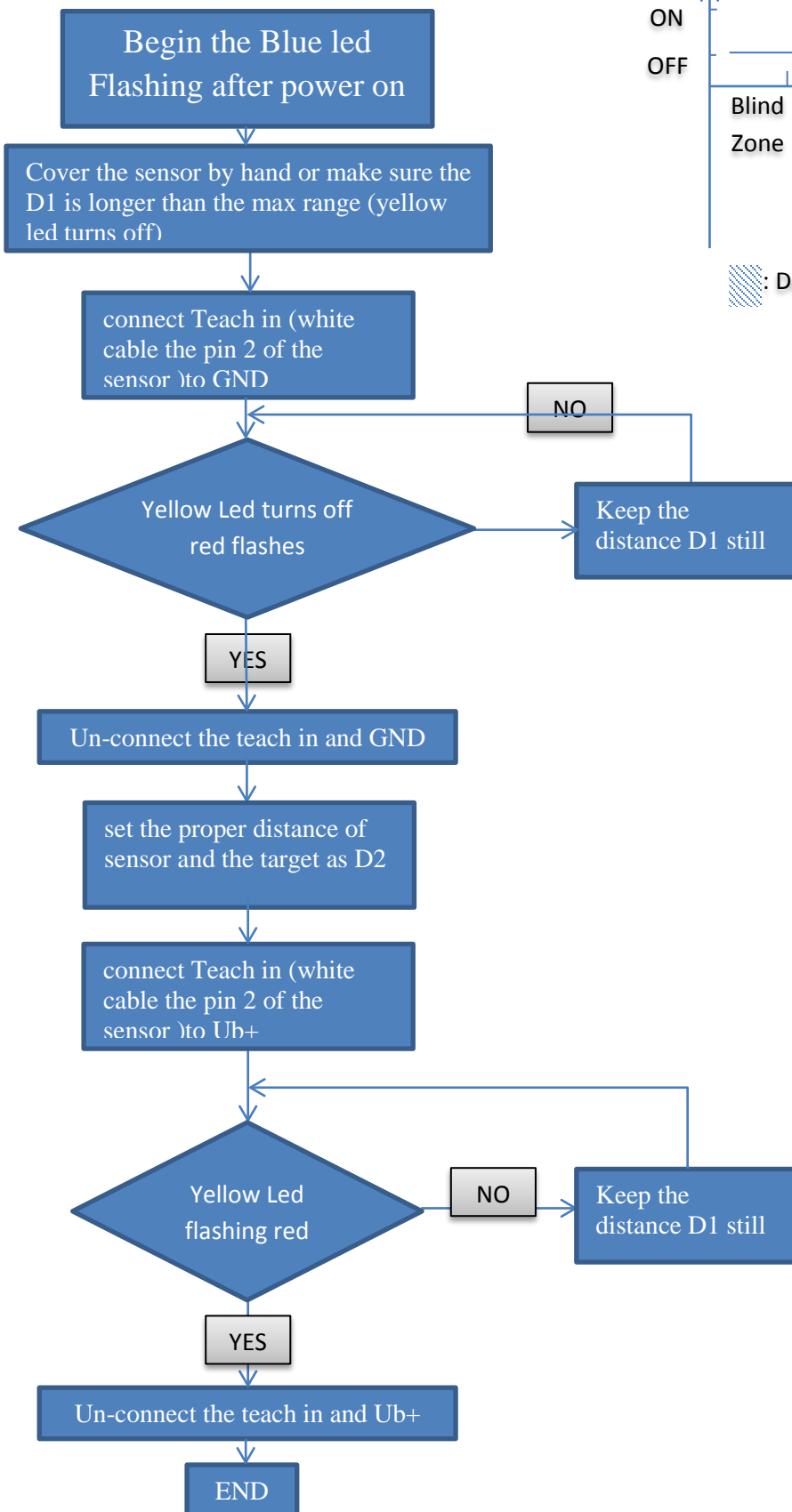
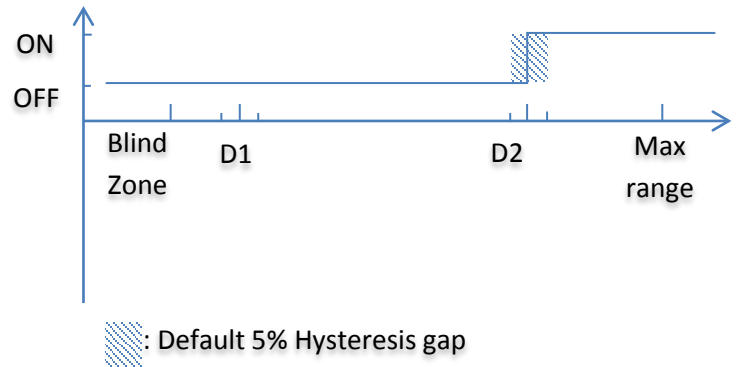

5), Single switch point with hysteresis gap normally-open function program routine diagram.

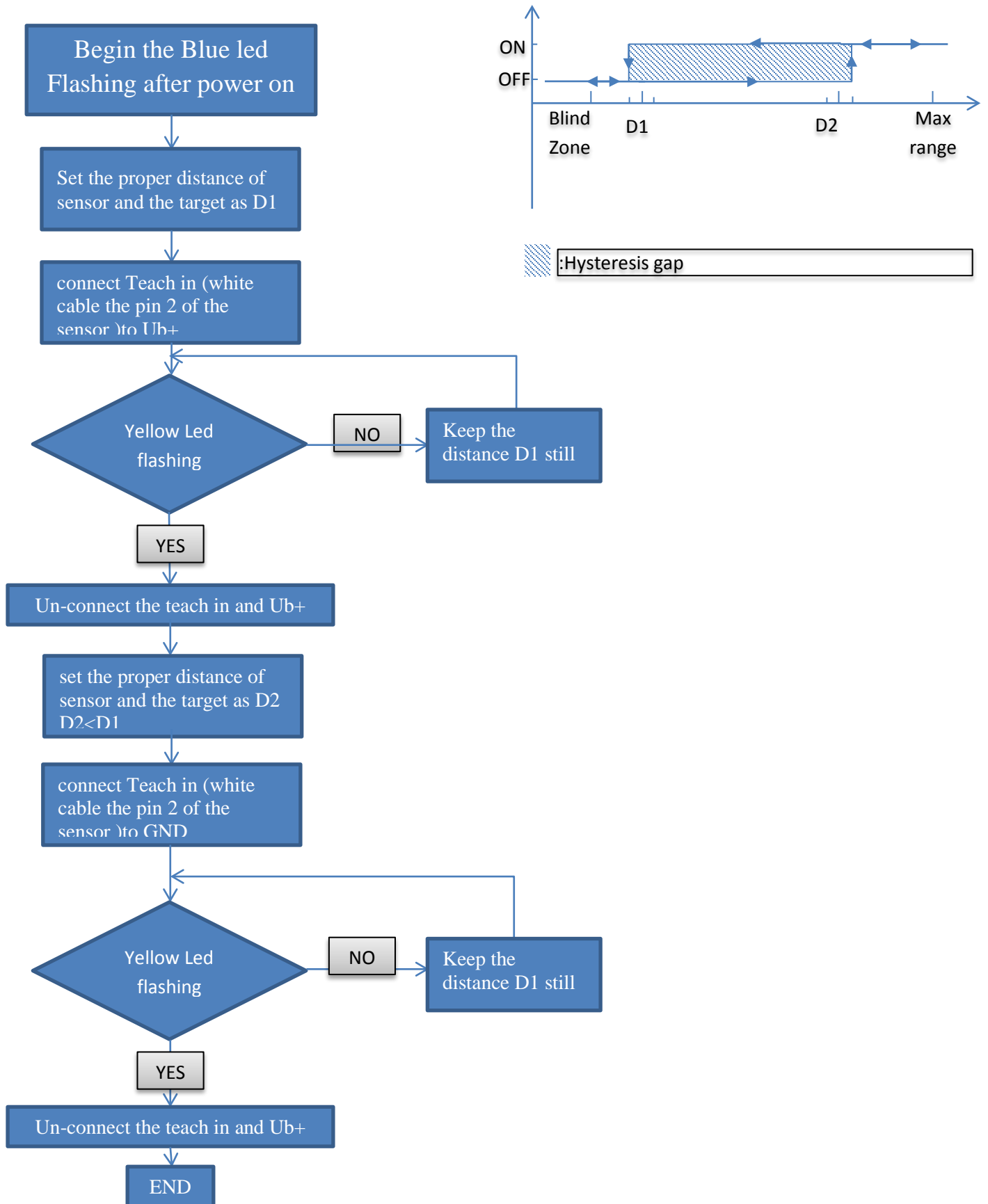

6), Single switch point with hysteresis gap normally-closed function program routine diagram.

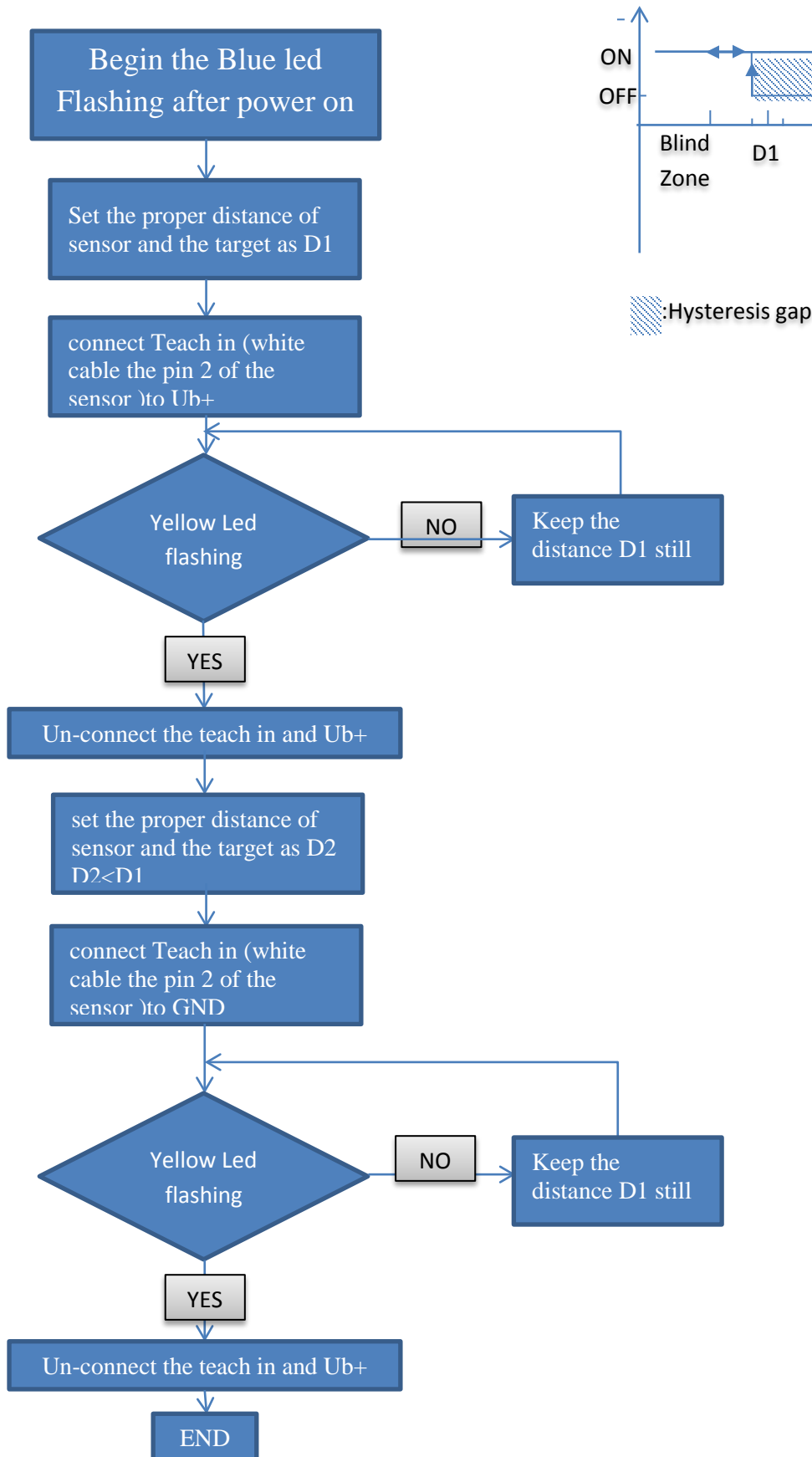

7), Detection of object presence-normal open function program routine diagram.

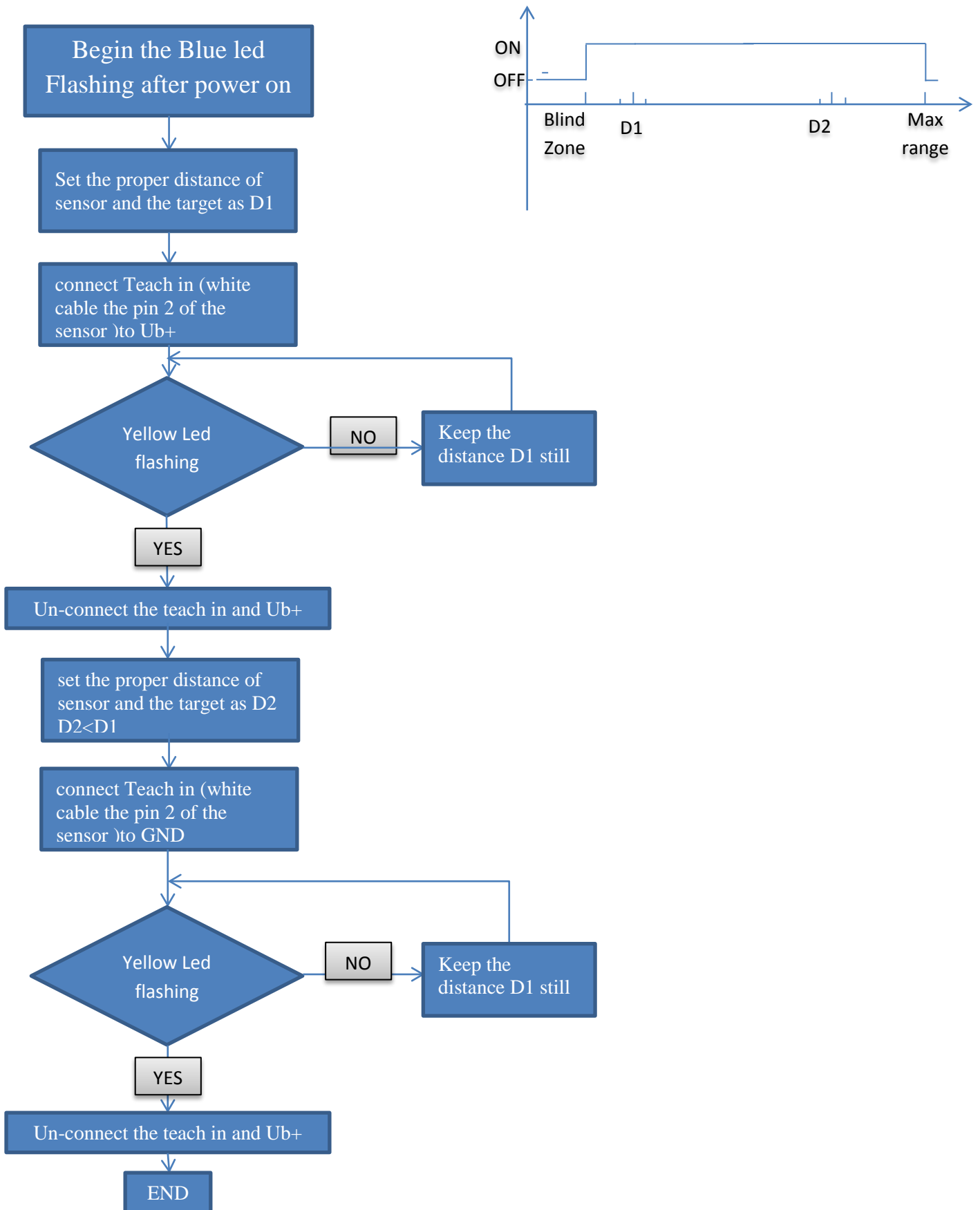

8), Detection of object presence-closed open function program routine diagram.

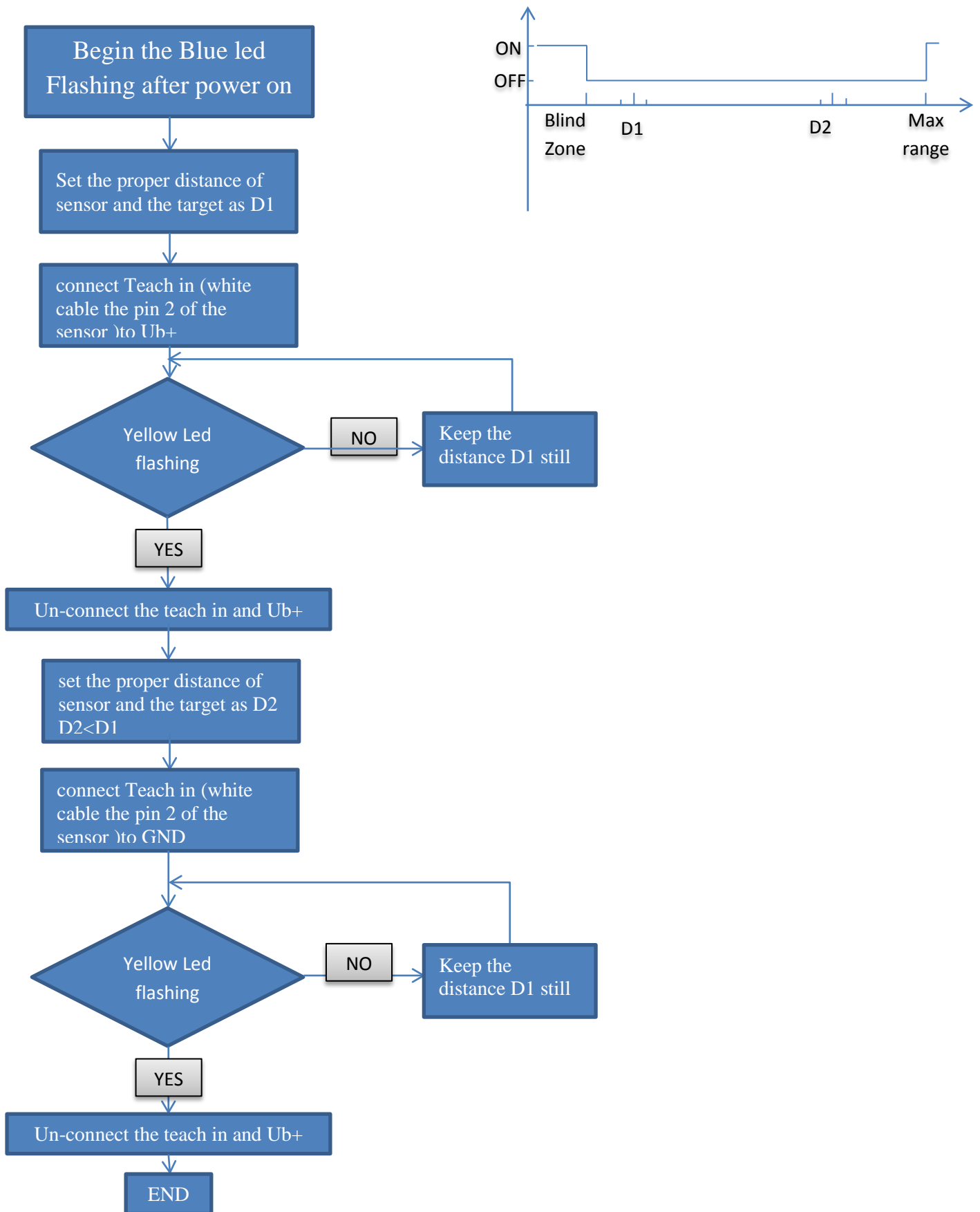

5. Installation conditions

If the sensor is installed at the environment temperature fall below 0°C, It should do well on the protective measures. In case of direct mounting of the sensor in a through hole using the steel nuts, it has to be fixed at the middle of the housing thread.

6. Ordering information

GXUS	Body size	OUTPUT	Max range	Description
	M18	For M18 body, The max range for M18 is 1000mm		
	M30-Type1	For M30 body. The max range is 2000mm for M30		
	M30-Type2	For M30 body. The max range is 3000mm for M30		
	M30-Type3	For M30 body. The max range is 6000mm for M30		
	Customized	Customized		
		NPN	Output is NPN	
		PNP	Output is PNP	
		Vout	Output is Vout 0-10V	
		mAout	Output is 4-20mA	
		RS485	Output is RS485	
			XXX mm	Xxx mm is the maxim range can be detected For M18 the max range is 1000mm For M30 the max range is 6000mm
GXUS	M30	RS485	2000mm	